

NE 4690



Swing-N-Slide®

Discovery Mountain

- For use with the
 Competitor® (NE 4438)
 Eagle's Nest™ Clubhouse (NE 4430)
 Covered Wagon™ Corral (NE 4425)
 Shuttle Tower™ (NE 4525)
 Titan™ (NE 4890)
- **LIFETIME WARRANTY**
 Lumber Required (sold separately)
 one (1) 2" x 4" x 8'
 one (1) 2" x 4" x 10'

Swing-N-Slide Corp
 Janesville, WI 53545
 Specifications Subject to Change
 Without Notice



LA 4546

Attention Consumer! This product is designed for use by children ages 2-10 years. However, since this is a climbing activity, consider the motor skill development and physical abilities of your child before allowing them to play on this equipment.

Safety First:

- Installation of proper shock absorbing material is required. Consult the owners manual of your original Swing-N-Slide kit for depth requirements. Extend surfacing material at least six (6) feet from both sides as well as the end of the wall to protect from falls. This is in addition to existing surfacing requirements of your play center. Failure to do so could result in serious bodily injury.
- The Sun: This product should not have a southern exposure unless it is shaded from the mid-day sun. Unshaded product facing south can get hot and cause discomfort to bare skin. Northern exposures or shaded areas are definitely best.
- Do not allow children to play on equipment when it is wet.
- On-site adult supervision must be provided at all times.

This is not a complete list of safety information. Consult the plan and guide of your original Swing-N-Slide kit for a complete list of safety instructions.

Maintenance:

- Occasionally check to make sure water drainage holes remain unplugged. Clean them if necessary.
- Do not allow debris or loose materials to accumulate on the steps.

Hardware Included (shown actual size)



sixteen (16) 3" screws



one (1) torx head bit

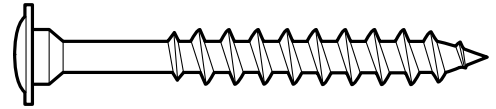

four (4) Torx Head screws

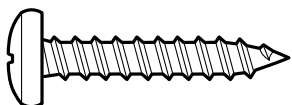

four (4) 1-1/4" panhead screws

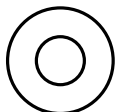

four (4) washers

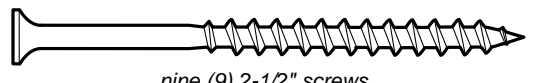
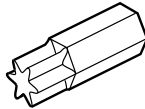

nine (9) 2-1/2" screws

Installation Instructions

Before beginning installation of the Discovery Mountain, alterations must be made to your existing climbing unit.

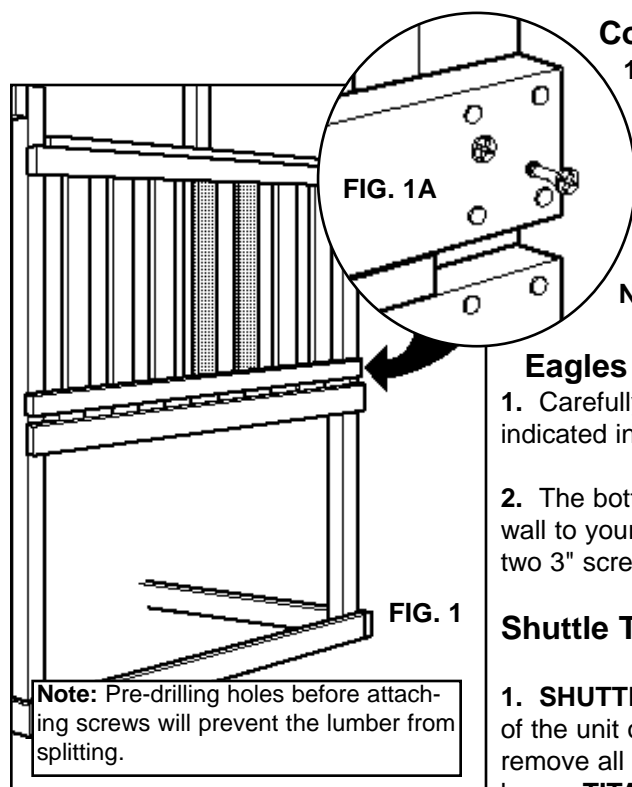

Competitor

1. Carefully remove the three center rails from the side of the unit opposite the swing beam. In addition, the support for accessories must be removed flush with the edge of the unit.
2. The bottom rail support must be reinforced before attaching the climbing wall to your play set. Reinforce the bottom rail support using a minimum of two 3" screws at each joint (see Fig 1A). **Note: Screws are included.**

Eagles Nest Clubhouse and Covered Wagon Corral

1. Carefully remove the third and fourth rails from the side of the unit as indicated in Fig. 1.
2. The bottom rail support must be reinforced before attaching the climbing wall to your play set. Reinforce the bottom rail support using a minimum of two 3" screws at each joint (see Fig 1A). **Note: Screws are included.**

Shuttle Tower and Titan Standard and Ultimate

1. **SHUTTLE TOWER:** Carefully remove the center three rails from the side of the unit opposite the ladder assembly. **TITAN STANDARD:** Carefully remove all rails of the lower deck from the side of the unit opposite the swing beam. **TITAN ULTIMATE:** See Titan Ultimate plan for more information.

2. The bottom rail support must be reinforced before attaching the climbing wall to your play set. Reinforce the bottom rail support using a minimum of two 3" screws at each joint (see Fig 1A). **Note: Screws are included.**

Note: Pre-drilling holes before attaching screws will prevent the lumber from splitting.

Installation Instructions

1. Cut your lumber as indicated. **Note:** The 18" pieces will be used as stakes and must be cut accordingly.

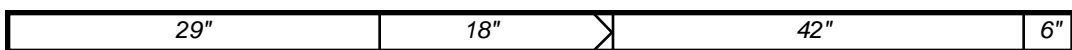

2" x 4" x 8'



2" x 4" x 10'

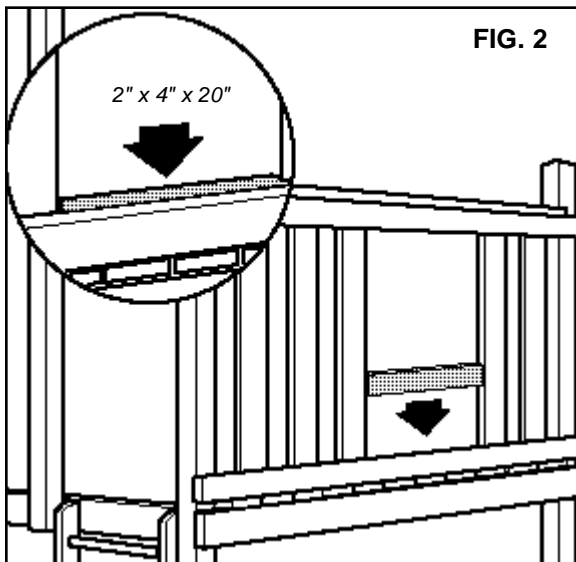

FIG. 2

3. Position the 2" x 4" x 20" piece of lumber inside the opening of your climbing unit as shown in Fig 2. Secure the board to the rail support using three evenly spaced 2-1/2" screws. **Note: Screws are included.**

4. Assemble the wall support as illustrated in Fig. 3. Use three 2-1/2" screws to attach the 2" x 4" x 6" boards and two 3" screws per joint for the remaining assembly. **Note: Screws are included.**

5. Place the top of the wall in front of the opening of the climbing unit. Align the right side of the wall with the right side of the opening of the unit. **Note:** The edge of the wall should be firmly positioned against the climbing unit (see Fig. 4). **Do not attach the wall at this time.**

6. Note the location of four holes in the sides of the wall (two each side). These holes will be used to secure the stakes and bracing. Mark the locations of these holes on the ground directly below the position of the holes on the wall. Remove the wall from the unit.

7. Dig two holes approximately 12" below grade at the hole locations closest to the slide (see Fig. 5).

8. Pound the 18" stakes into the ground at the proper hole locations. Leave approximately 6" of each stake above grade. Level the grade around the stakes to assure the base of the wall is securely seated.

9. Reposition the wall in the opening of the climbing unit. Align the right side of the wall with the right side of the opening of the unit. The edge of the wall should be firmly positioned against the climbing unit and the stakes should be inside the base of the wall. Secure the wall to the rail using four Torx head screws as indicated in Fig. 4. **Note:** Use the included Torx Head bit and an electric drill to drive the screws into the rail. Secure the base to the stakes using one 1-1/4" panhead screw and washer per joint (see Fig. 5A).

10. Place the brace beneath the wall. Position the legs in the holes dug previously and adjust the brace until the brace lines up with the holes of the wall. Attach the wall to the brace using one 1-1/4" panhead screw and washer per joint (see Fig. 5A). Square the brace to the ground. **Note:** The bottom rail of the brace should rest firmly on the ground. Adjust the grade as required. Fill in each of the holes and level the surrounding grade.

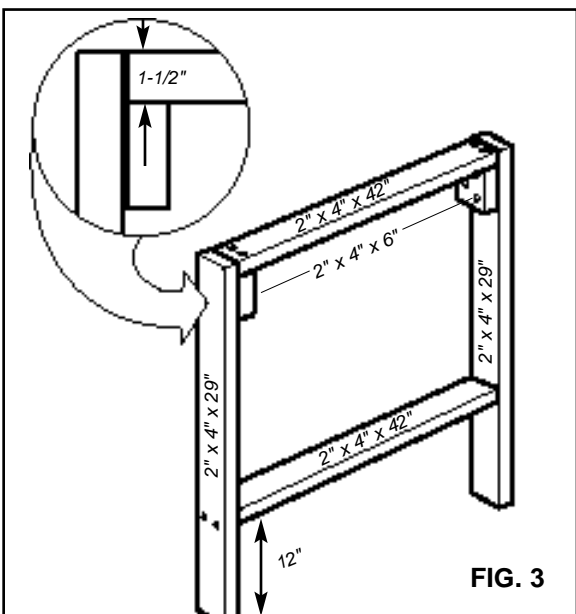

FIG. 3

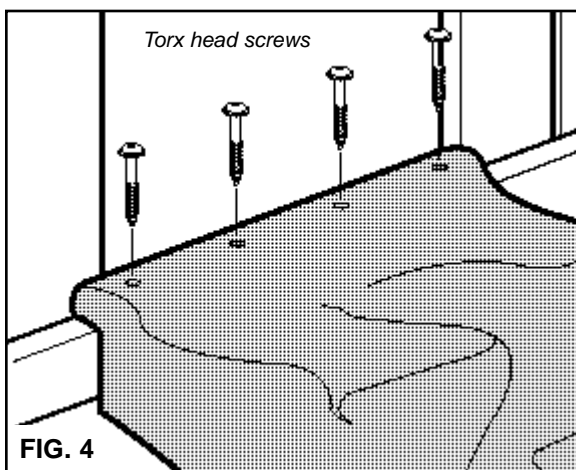

FIG. 4

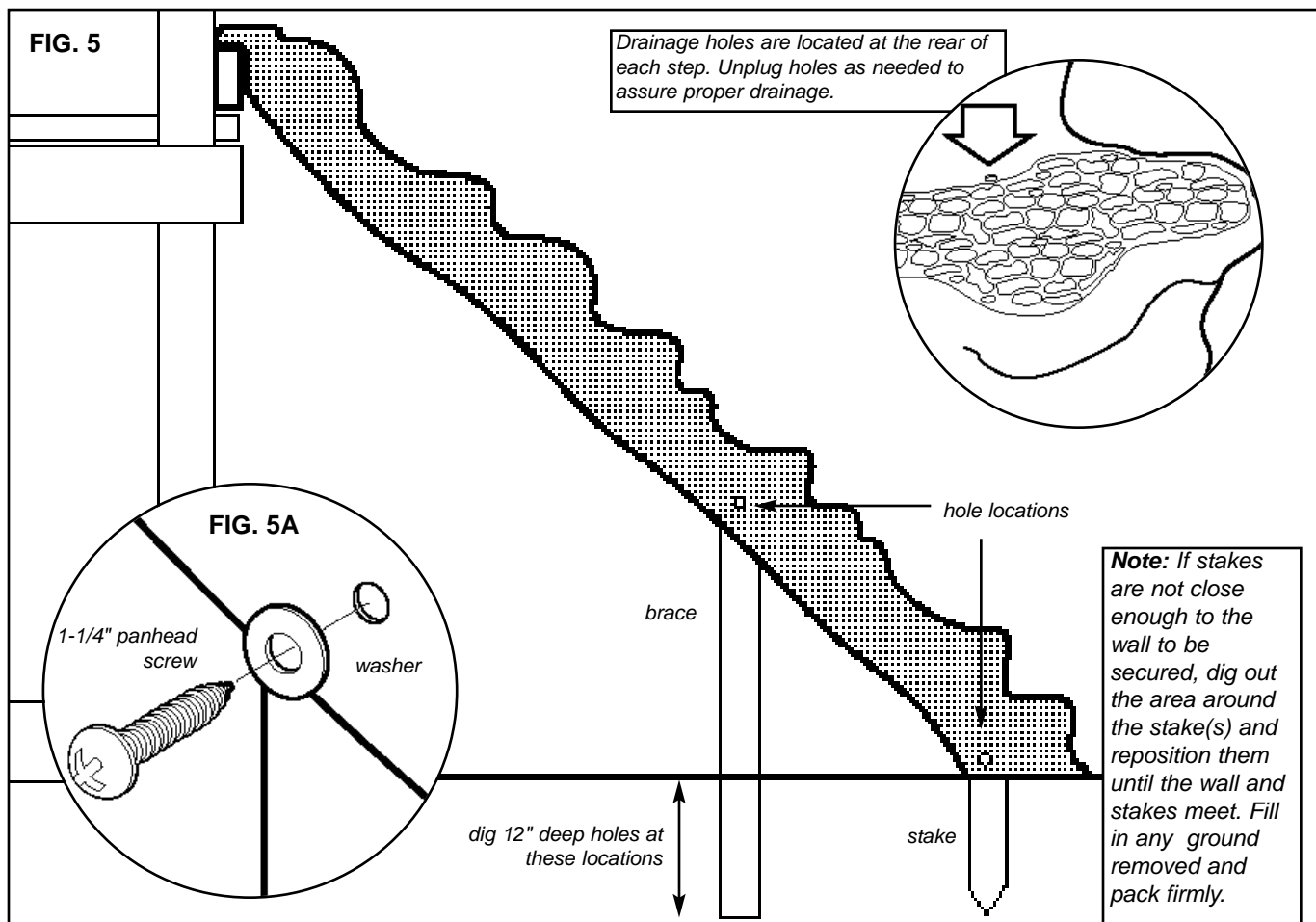

FIG. 5

Drainage holes are located at the rear of each step. Unplug holes as needed to assure proper drainage.

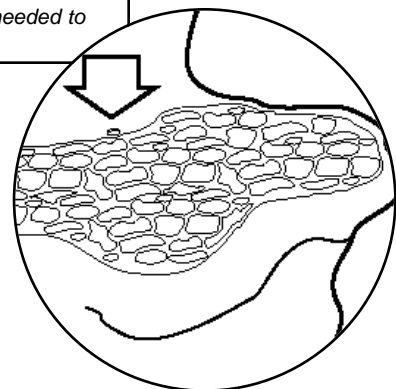
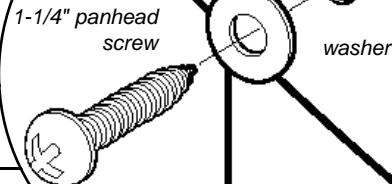

FIG. 5A



dig 12" deep holes at these locations

hole locations

brace

stake

Note: If stakes are not close enough to the wall to be secured, dig out the area around the stake(s) and reposition them until the wall and stakes meet. Fill in any ground removed and pack firmly.

If you are missing parts or have any questions concerning assembly, please call us at: 1-800-888-1232.